

For Sale

Attractive Commercial Building located in the Queens Quarter
60 University Street, Belfast BT7 1HB



CUSHMAN &
WAKEFIELD



McCOMBE
PIERCE



For Sale

60 University Street, Belfast BT7 1HB



Summary

- Attractive 3 storey commercial property located in the Queens Quarter
- Accommodation extends to 1,914 sq.ft approx.
- Part income producing with potential to increase upon letting the vacant space
- Suitable for investors / owner occupiers
- Guide Price: £245,000 exclusive

Location

University Street links the Ormeau Road with University Road and runs through the heart of the University area in South Belfast. The subject property occupies a prominent position on University Street between the junction with Botanic Ave and Wolseley St in close proximity to Queen's University.

Surrounding occupiers include Ibis Hotel, Dukes Hotel, Fitzroy Church, Key Lets Estate Agents and a range of retailers and restaurants on Botanic Avenue and University Road.

Description

The subject is an attractive Mid-Terrace commercial building arranged over 3 storeys. The property is Grade B2 Listed (HB26/27/049/A). Internally the property is well presented with finishes to include a combination of wooden / laminate / carpeted floors, plastered & painted walls, feature lighting, many original ornate features on the ground and first floor levels and the property also benefits from GFCH.

The property may also be suitable for a residential conversion with other neighbouring properties have been converted into apartments / short-stay accommodation.

The ground and first floors are both currently let on a 5 year lease from 01/09/22 with the rent increasing to £12,000 p.a in Sept 24. There is a further rent increase due in Sept 26 to £14,400 p.a. The top floor is currently vacant and would be suitable for an owner occupier or tenant.

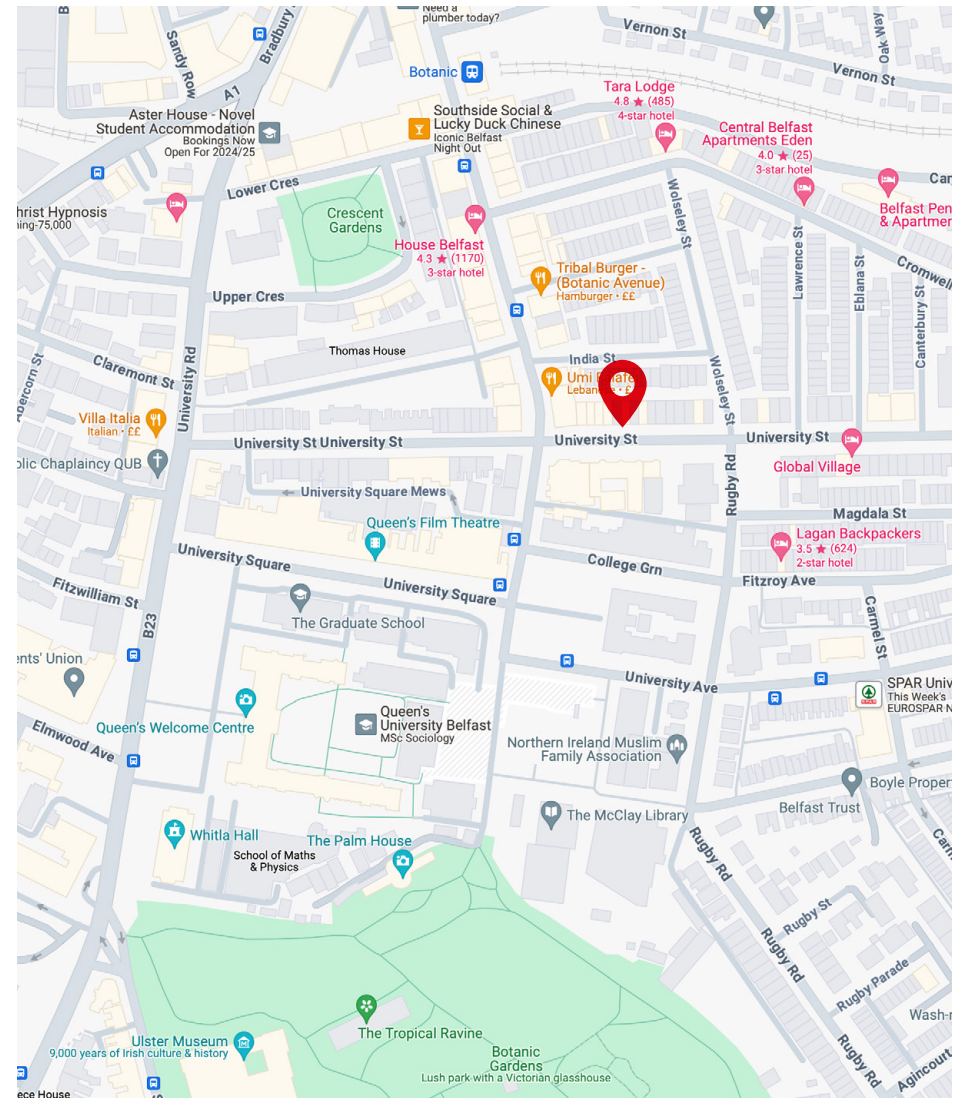

For Sale

60 University Street, Belfast BT7 1HB



Accommodation/Areas

The approximate Net Internal Areas of the property are as follows:

Floor	Description	Sq M	Sq Ft
Ground Floor	Entrance lobby, Front Treatment room, rear treatment room, staff, kitchen, WC & Storage.	59.29	638
First Floor	Front Treatment Room, Middle Treatment Room, WC & Shower, Rear treatment room.	52.96	570
Second Floor	Front Office, WC and rear office suite	65.55	706
Total		177.80	1,914

Non Domestic Rates

The subject property has the following LPS rating assessments:

Floor	NAV	Payable 24/25
Ground & First Floor	£12,100	£4,889.92*
Second Floor	£5,300	£3,116.68**
Combined	£17,300	£8,006.60

The rate in the pound for 2024/25 for Belfast is £0.599362.

*Reflects the Small Business Rate Relief & Empty Premises Relief

**The occupier may be able to avail of Small Business Rates Relief which would result in a further rates reduction. Given the listed status of 60 University Street, rates should not be payable whilst the building is vacant.

Guide Price

Offers invited in the region of £245,000 exclusive.

VAT

All figures quoted are exclusive of VAT, which may be payable.



For Sale
60 University Street, Belfast BT7 1HB



For Sale
60 University Street, Belfast BT7 1HB



University Road

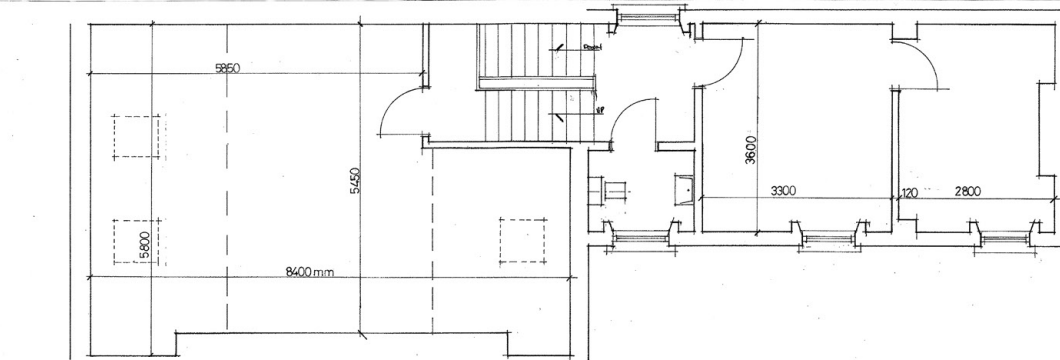

Second Floor Plan

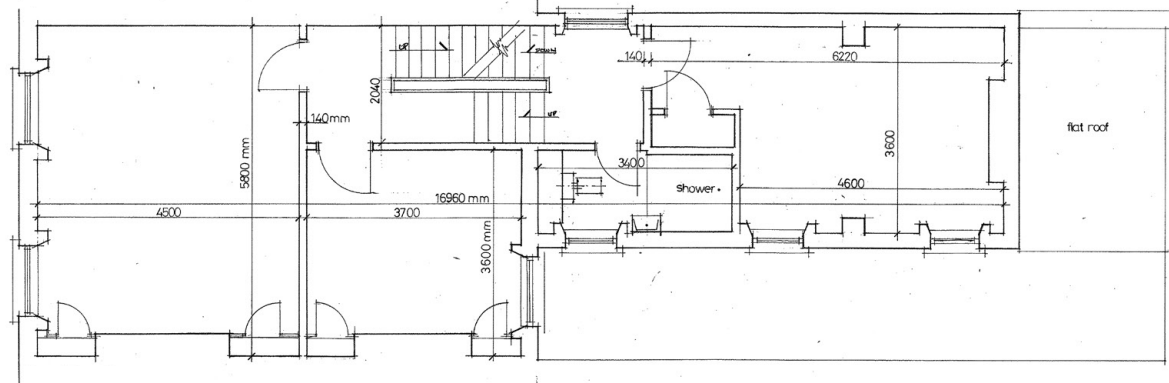

First Floor Plan

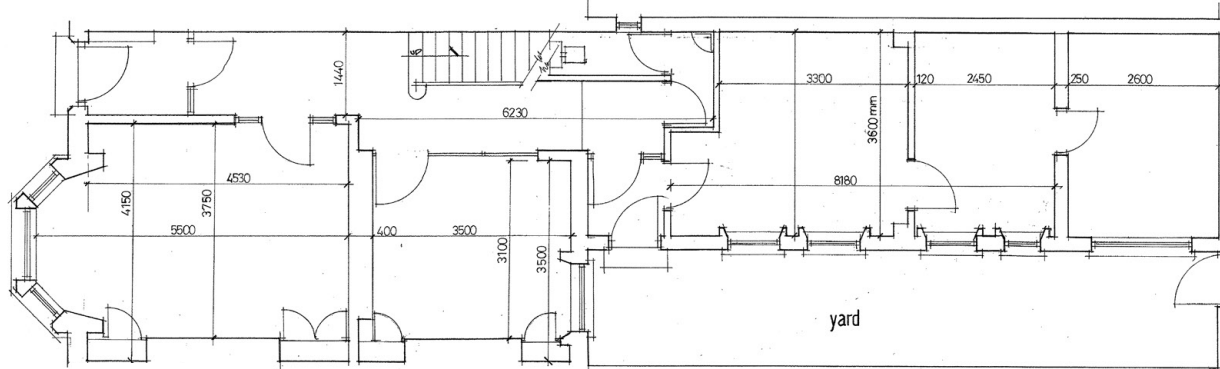

Ground Floor Plan

EPC

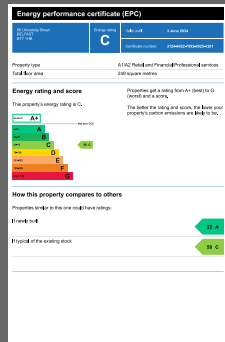

McCombe Pierce LLP

Lombard House, 10-20 Lombard Street, Belfast BT1 1RD

+44 (0)28 9023 3455

www.cushmanwakefield-ni.com

For more information, please contact:

Martin McKibbin

028 9023 3455

martin.mckibbin@cushwake-ni.com

James Russell

028 9023 3455

james.russell@cushwake-ni.com

Billy Scott

028 9023 3455

billy.scott@cushwake-ni.com



Disclaimer

"McCombe Pierce LLP (and its subsidiaries and their joint Agents where applicable) for themselves and for the vendors or lessors of this property for whom they act, give notice that:

- (i) these particulars are a general outline only, for the guidance of prospective purchasers or tenants, and do not constitute the whole or any part of an offer or contract; McCombe Pierce LLP cannot guarantee the accuracy of any description, dimensions, references to condition, necessary permissions for use and occupation and other details contained herein and prospective purchasers or tenants must not rely on them as statements of fact or representations and must satisfy themselves as to their accuracy;
- (ii) no employee of McCombe Pierce LLP (and its subsidiaries and their joint Agents where applicable) has any authority to make or give any representation or warranty or enter into any contract whatever in relation to the property;
- (iii) rents quoted in these particulars may be subject to VAT in addition;
- (iv) McCombe Pierce LLP (and its subsidiaries where applicable) will not be liable, in negligence or otherwise, for any loss arising from the use of these particulars; and the reference to any plant, machinery, equipment, services, fixtures or fittings at the property shall not constitute a representation (unless otherwise stated) as to its state or condition or that it is capable of fulfilling its intended function. Prospective purchasers/tenants should satisfy themselves as to the fitness of such items for their requirements."

Customer due diligence:

As a business carrying out estate agency work we are required to verify the identity of both the vendor and purchaser as outlined in The Money Laundering, Terrorist Financing and Transfer of Funds (Information on the Payer) Regulations 2017 - <http://www.legislation.gov.uk/ukSI/2017/692/made>. Any information and documentation provided by you will be held for a period of five years from when you cease to have a contractual relationship with McCombe Pierce LLP. The information will be held in accordance with the General Data Protection Regulation (GDPR) on our client file and will not be passed to any other party, unless we are required to do so by law and regulation.